



# Test Report: PCD-16-350B

---

16W Single Output AC Dimmable LED Power Supply

## ■ DESIGN VERIFY TEST

Output Function Test

Input Function Test

Protection Function Test

Component Stress Test

## ■ SAFETY & E.M.C. TEST

Safety Test

E.M.C. Test

## ■ RELIABILITY TEST

ENVIRONMENT TEST

**DESIGN VERIFY TEST**
**OUTPUT FUNCTION TEST**

NO	TEST ITEM	SPECIFICATION	TEST CONDITION	RESULT	VERDICT
1	RIPPLE & NOISE	V1 : 4.6 Vp-p (Max)	I/P : 230VAC O/P : FULL LOAD Ta : 25°C	V1 : 1.34 Vp-p (Max)	P
2	SET UP TIME	230VAC : 1000 ms (Max)	I/P : 230 VAC O/P : FULL LOAD Ta : 25°C	230VAC/ 675 ms	P
3	OPERATING VOLTAGE RANGE	24V~48V	I/P : 230VAC O/P : CV MODE Ta : 25°C	O/P= 24V : 0.36 A O/P= 47V : 0.36 A	P
4	OVER/UNDERSHOOT TEST	< 63V	I/P : 230 VAC O/P : FULL LOAD Ta : 25°C	TEST : < 63 V	P

**INPUT FUNCTION TEST**

NO	TEST ITEM	SPECIFICATION	TEST CONDITION	RESULT	VERDICT
1	INPUT VOLTAGE RANGE	180VAC~295 VAC	I/P : TESTING O/P : FULL LOAD Ta : 25°C  I/P : LOW-LINE-3V= 177 V HIGH-LINE+15%=300 V O/P : FULL/MIN LOAD ON : 30 Sec. OFF : 30 Sec 10MIN ( AC POWER ON/OFF NO DAMAGE )	138 V~295V  TEST : OK	P
2	INPUT FREQUENCY RANGE	47HZ ~63 HZ NO DAMAGE OSC	I/P : 180 VAC ~ 295 VAC O/P : FULL -MIN LOAD Ta : 25°C	TEST : OK	P
3	POWER FACTOR	0.9 / 230 VAC(TYP) 0.9 / 180 VAC(TYP) 0.9 / 277 VAC(TYP)	I/P : 230 VAC (FULL LOAD) I/P : 180 VAC (FULL LOAD) I/P : 277 VAC (FULL LOAD) O/P : FULL LOAD Ta : 25°C	PF= 0.971 / 230 VAC PF= 0.989 / 180 VAC PF= 0.91 / 277 VAC	P
4	EFFICIENCY	82 % (TYP)	I/P : 230 VAC O/P : FULL LOAD Ta : 25°C	82.68 %	P
5	INPUT CURRENT	230V/ 0.2 A (TYP)	I/P : 230 VAC O/P : FULL LOAD Ta : 25°C	I = 0.09 A/ 230 VAC	P
6	INRUSH CURRENT	230V/ 10 A (TYP) COLD START	I/P : 230 VAC  O/P : FULL LOAD Ta : 25°C	I = 7 A/ 230 VAC	P
7	LEAKAGE CURRENT	< 0.5 mA / 240 VAC	I/P : 240 VAC O/P : Min LOAD Ta : 25°C	L-CASE : 0.01 mA N-CASE : 0.01 mA	P

8 AC Dimming Operation

The following diagram depicts a typical installation utilizing the PCD-25:

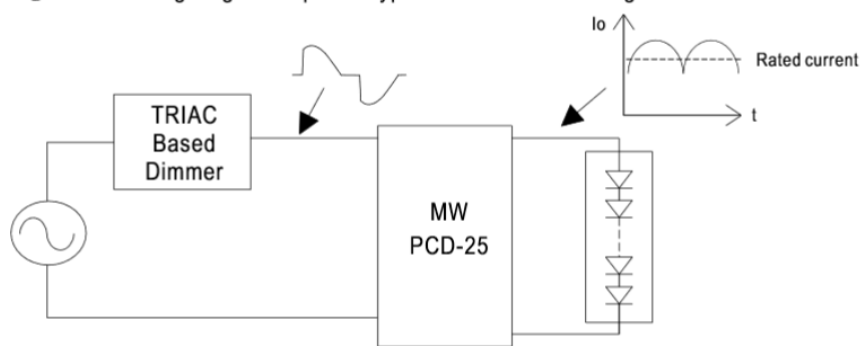

Under direct driving, the power supply will work in "constant current mode (CC)" and output voltage of the power supply will be clamped by sum of forward voltage (V) of the LED strip.

Test condition:

I/P : Atype:120VAC Btype:220VAC~277VAC

O/P : Testing

Ta : 25°C

Dimmer Compatibility Chart:

Manufacturer	Dimmer Model	
LUTRON	SKYLARK SF-12P-277	(277VAC / 60Hz)
LUTRON	DVF-103P-277	(277VAC / 60Hz)
LUTRON	SKYLARK SF-10P	(120VAC / 60Hz)
LUTRON	SKYLARK S-600P	(120VAC / 60Hz)
LUTRON	SKYLARK DVF-103P	(120VAC / 60Hz)
LEVITON	ILLUMATECH TM Cat.No.IP106	(120VAC / 60Hz)
LEVITON	SURESLIDE TM Cat.No.6633-P	(120VAC / 60Hz)
LEVITON	SURESLIDE TM Cat. NO.6615-P	(120VAC / 60Hz)
JUNG	Licht-Management 225 TDE	(230VAC / 50Hz)
JUNG	Licht-Management 225 NV DE	(230VAC / 50Hz)
BERKER	Tronic-Drehdimmer 286710	(230-240VAC / 50Hz)
Bodo Ehmann LICHTREGLER	T39.01	(230VAC / 50Hz)
CLIPSAL	32E450UDM	(220-240VAC / 50Hz)
CLIPSAL	NO 32E450TM	(220-240VAC / 50Hz)

Test result:

Conduction angle: 30 degrees(min.) / 180 degrees(max.)

P

## PROTECTION FUNCTION TEST

NO	TEST ITEM	SPECIFICATION	TEST CONDITION	RESULT	VERDICT
1	OVER LOAD PROTECTION	95 % - 110 %	I/P : 230 VAC I/P : 180 VAC O/P : TESTING Ta : 25°C	105 %/ 230 VAC 105 %/ 180 VAC Constant Current Limiting recovers automatically after fault condition is removed.	P
2	OVER TEMPERATURE PROTECTION	SPEC : RTH1 : 95 ± 10°C O.T.P. Detect on heatsink of power transistor	I/P : 230 VAC O/P : FULL LOAD	O.T.P. Active Shut down o/p voltage · Re-power ON to recover	P
3	SHORT PROTECTION	SHORT EVERY OUTPUT 1 HOUR NO DAMAGE	I/P : 295 VAC O/P : FULL LOAD Ta : 25°C	NO DAMAGE	P

## COMPONENT STRESS TEST

NO	TEST ITEM	SPECIFICATION	TEST CONDITION	RESULT	VERDICT
1	Power Transistor ( D to S ) or ( C to E ) Peak Voltage	Q 1 Rated : STD4NK80ZT4 3A/800V	I/P : High-Line +3V = 298 V O/P : (1) Full Load Turn on (2) Output Short (3) Full load continue Ta : 25°C	(1) 560 V (2) 464 V (3) 540 V	P
2	Diode Peak Voltage	D100 Rated : NSF03A40 3A/400V	I/P : High-Line +3V = 298 V O/P : (1) Full Load Turn on (2) Output Short (3) Full load continue Ta : 25°C	(1) 338 V (2) 334 V (3) 310 V	P
3	Clamp Diode Peak Voltage	D 6 Rated : 1A/1KV 1N4007GP	I/P : High-Line +3V = 298 V O/P : (1) Full Load Turn on (2) Output Short (3) Full load continue Ta : 25°C	(1) 580 V (2) 440 V (3) 576 V	P
4	Control IC Voltage Test	U 1 Rated : PWM NCP1608B 10.2V~20V	I/P : High-Line +3V = 298 V O/P : (1) Full Load Turn on /Off (2) Min load Turn on /Off (3) Full Load /Min load Change Ta : 25°C	(1) 13.853 V (2) 13.675 V (3) 13.576 V	P

**SAFETY & E.M.C. TEST**
**SAFETY TEST**

NO	TEST ITEM	SPECIFICATION	TEST CONDITION	RESULT	VERDICT
1	WITHSTAND VOLTAGE	I/P-O/P : 3.75 KVAC/min	I/P-O/P : 4 KVAC/min Ta : 25°C	I/P-O/P : 1.17 mA NO DAMAGE	P
2	ISOLATION RESISTANCE	I/P-O/P : 500VDC>100MΩ	I/P-O/P : 500 VDC Ta : 25°C/70%RH	I/P-O/P : 30 GΩ NO DAMAGE	P
3	APPROVAL	TUV : Certificate NO : UL : File NO :			N/A

**E.M.C TEST**

NO	TEST ITEM	SPECIFICATION	TEST CONDITION	RESULT	VERDICT
1	HARMONIC	EN61000-3-2 CLASS C	I/P:230 /240//220VAC/50HZ LOAD:LED/ELECTRONIC LOAD O/P:40V/58VLOAD Ta:25°C	PASS	P
2	CONDUCTION	EN55015 CLASS B	I/P : 230 VAC (50HZ) O/P : FULL/50% LOAD Ta : 25°C	PASS Test by certified Lab	P
3	RADIATION	EN55015 CLASS B	I/P : 230 VAC (50HZ) O/P : FULL LOAD Ta : 25°C	PASS Test by certified Lab	P
4	E.S.D	EN61000-4-2 LIGHT INDUSTRY AIR : 8KV / Contact : 4KV	I/P : 230 VAC/50HZ O/P : FULL LOAD Ta : 25°C	CRITERIA A	P
5	E.F.T	EN61000-4-4 LIGHT INDUSTRY INPUT : 1KV	I/P : 230 VAC/50HZ O/P : FULL LOAD Ta : 25°C	CRITERIA A	P
6	SURGE	IEC61000-4-5 LIGHT INDUSTRY L-N : 1KV	I/P : 230 VAC/50HZ O/P : FULL LOAD Ta : 25°C	CRITERIA A	P
7	Test by certified Lab & Test Report Prepare				

**RELIABILITY TEST**
**ENVIRONMENT TEST**

NO	TEST ITEM	SPECIFICATION	TEST CONDITION	RESULT	VERDICT																																																																																															
1	TEMPERATURE RISE TEST	MODEL : PCD-16-1400B 1. ROOM AMBIENT BURN-IN : 1 HRS I/P : 230VAC O/P : FULL LOAD Ta=30.3°C 2. HIGH AMBIENT BURN-IN : 3.5 HRS I/P : 230VAC O/P : FULL LOAD Ta=50°C			<b>P</b>																																																																																															
		<table border="1"> <thead> <tr> <th>NO</th> <th>Position</th> <th>P/N</th> <th>ROOM AMBIENT Ta= 30.3 °C</th> <th>HIGH AMBIENT Ta= 50 °C</th> </tr> </thead> <tbody> <tr><td>6</td><td>LF1</td><td>LF804</td><td>61.3°C</td><td>75.4°C</td></tr> <tr><td>7</td><td>L1</td><td>TF2170</td><td>62.2°C</td><td>76.1°C</td></tr> <tr><td>8</td><td>BD1</td><td>2A/800V GLASS KBP208G</td><td>64.3°C</td><td>78.2°C</td></tr> <tr><td>9</td><td>C9</td><td>333/630V 10% P=7.5 MEX</td><td>59.1°C</td><td>73.4°C</td></tr> <tr><td>10</td><td>R1</td><td>3W 22KΩ 5% MINI</td><td>87.3°C</td><td>101.4°C</td></tr> <tr><td>11</td><td>R5</td><td>3W 330Ω 5% MINI</td><td>64.5°C</td><td>78.4°C</td></tr> <tr><td>12</td><td>C1</td><td>104/275VAC 20% P=10 R.46</td><td>69.1°C</td><td>82.6°C</td></tr> <tr><td>13</td><td>D30</td><td>HER204 2A/300V</td><td>66.2°C</td><td>80.3°C</td></tr> <tr><td>14</td><td>C48</td><td>22u/50V UL10Kh 5*11 YXM</td><td>66.1°C</td><td>80.1°C</td></tr> <tr><td>15</td><td>TSW1</td><td>220KΩ 3Φ TTC3A224F4371EY 1%</td><td>62.2°C</td><td>77.0°C</td></tr> <tr><td>16</td><td>T1</td><td>TF2146</td><td>73.1°C</td><td>87.0°C</td></tr> <tr><td>17</td><td>U1</td><td>NCP1608B</td><td>65.2°C</td><td>79.3°C</td></tr> <tr><td>18</td><td>Q1</td><td>STD4NK80ZT4 3A/800V DPAK</td><td>70.4°C</td><td>84.7°C</td></tr> <tr><td>19</td><td>C7</td><td>333/450V 10% P=7.5 MEC</td><td>68.1°C</td><td>81.9°C</td></tr> <tr><td>20</td><td>D100</td><td>B5100C 5A/100V SMC</td><td>77.0°C</td><td>90.7°C</td></tr> <tr><td>21</td><td>C105</td><td>2200u/16V UL10Kh 12.5*20 ZLH</td><td>62.0°C</td><td>76.5°C</td></tr> <tr><td>22</td><td>C54</td><td>33u/50V UL10Kh 6.3*11 YXM</td><td>63.0°C</td><td>77.1°C</td></tr> <tr><td>23</td><td>LF100</td><td>TR574-R2</td><td>57.4°C</td><td>72.6°C</td></tr> </tbody> </table>	NO	Position		P/N	ROOM AMBIENT Ta= 30.3 °C	HIGH AMBIENT Ta= 50 °C	6	LF1	LF804	61.3°C	75.4°C	7	L1	TF2170	62.2°C	76.1°C	8	BD1	2A/800V GLASS KBP208G	64.3°C	78.2°C	9	C9	333/630V 10% P=7.5 MEX	59.1°C	73.4°C	10	R1	3W 22KΩ 5% MINI	87.3°C	101.4°C	11	R5	3W 330Ω 5% MINI	64.5°C	78.4°C	12	C1	104/275VAC 20% P=10 R.46	69.1°C	82.6°C	13	D30	HER204 2A/300V	66.2°C	80.3°C	14	C48	22u/50V UL10Kh 5*11 YXM	66.1°C	80.1°C	15	TSW1	220KΩ 3Φ TTC3A224F4371EY 1%	62.2°C	77.0°C	16	T1	TF2146	73.1°C	87.0°C	17	U1	NCP1608B	65.2°C	79.3°C	18	Q1	STD4NK80ZT4 3A/800V DPAK	70.4°C	84.7°C	19	C7	333/450V 10% P=7.5 MEC	68.1°C	81.9°C	20	D100	B5100C 5A/100V SMC	77.0°C	90.7°C	21	C105	2200u/16V UL10Kh 12.5*20 ZLH	62.0°C	76.5°C	22	C54	33u/50V UL10Kh 6.3*11 YXM	63.0°C	77.1°C	23	LF100	TR574-R2	57.4°C	72.6°C		
NO	Position	P/N	ROOM AMBIENT Ta= 30.3 °C	HIGH AMBIENT Ta= 50 °C																																																																																																
6	LF1	LF804	61.3°C	75.4°C																																																																																																
7	L1	TF2170	62.2°C	76.1°C																																																																																																
8	BD1	2A/800V GLASS KBP208G	64.3°C	78.2°C																																																																																																
9	C9	333/630V 10% P=7.5 MEX	59.1°C	73.4°C																																																																																																
10	R1	3W 22KΩ 5% MINI	87.3°C	101.4°C																																																																																																
11	R5	3W 330Ω 5% MINI	64.5°C	78.4°C																																																																																																
12	C1	104/275VAC 20% P=10 R.46	69.1°C	82.6°C																																																																																																
13	D30	HER204 2A/300V	66.2°C	80.3°C																																																																																																
14	C48	22u/50V UL10Kh 5*11 YXM	66.1°C	80.1°C																																																																																																
15	TSW1	220KΩ 3Φ TTC3A224F4371EY 1%	62.2°C	77.0°C																																																																																																
16	T1	TF2146	73.1°C	87.0°C																																																																																																
17	U1	NCP1608B	65.2°C	79.3°C																																																																																																
18	Q1	STD4NK80ZT4 3A/800V DPAK	70.4°C	84.7°C																																																																																																
19	C7	333/450V 10% P=7.5 MEC	68.1°C	81.9°C																																																																																																
20	D100	B5100C 5A/100V SMC	77.0°C	90.7°C																																																																																																
21	C105	2200u/16V UL10Kh 12.5*20 ZLH	62.0°C	76.5°C																																																																																																
22	C54	33u/50V UL10Kh 6.3*11 YXM	63.0°C	77.1°C																																																																																																
23	LF100	TR574-R2	57.4°C	72.6°C																																																																																																
2	LOW TEMPERATURE TURN ON TEST	TURN ON AFTER 2 HOUR	I/P : 230VAC/100VAC O/P : 100 % LOAD Ta= -30 °C	TEST : OK		<b>P</b>																																																																																														
3	HIGH HUMIDITY HIGH TEMPERATURE HIGH VOLTAGE TURN ON TEST	AFTER 12 HOURS IN CHAMBER ON CONTROL 50 °C NO DAMAGE	I/P : 295 VAC O/P : FULL LOAD Ta= 50 °C HUMIDITY= 95 %R.H	TEST : OK		<b>P</b>																																																																																														
4	TEMPERATURE COEFFICIENT	± 0.03 %(0-50°C)	I/P : 230 VAC O/P : FULL LOAD	± 0.005 %(0-50°C)		<b>P</b>																																																																																														
5	STORAGE TEMPERATURE TEST	1. Thermal shock Temperature : -45°C~ +90°C 2. Temperature change rate : 25°C / MIN 3. Dwell time low and high temperature : 30 MIN/EACH 4. Total test cycle : 5 CYCLE 5. Input/Output condition : STATIC		OK	<b>P</b>																																																																																															
6	THERMAL SHOCK TEST	1. Thermal shock Temperature : -30°C~ +50°C 2. Temperature change rate : 25°C / MIN 3. Dwell time low and high temperature : 30 MIN/EACH 4. Total test cycle : 10 CYCLE 5. Input/Output condition : 230VAC/Full Load AC ON/OFF TEST turn on 58sec ; turn off 2sec		OK	<b>P</b>																																																																																															

7	VIBRATION TEST	1 Carton & 1 Set (1) Waveform : Sine Wave (2) Frequency : 10-500Hz (3) Sweep Time : 12min/sweep cycle (4) Acceleration : 2G (5) Test Time : 72min in each axis (X.Y.Z) (6) Ta : 25°C	TEST : OK	P
8	CAPACITOR LIFE CYCLE	PCD-16-1400B:SUPPOSE C105 IS THE MOST CRITICAL COMPONENT (1) I/P : 230VAC O/P : FULL LOAD Ta= 25 °C LIFE TIME (2) I/P : 230VAC O/P : FULL LOAD Ta= 50 °C LIFE TIME	(1) 347252 HRS (2) 88034 HRS	P
9	MTBF	MIL-HDBK-217F NOTICES2 PARTS COUNT TOTAL FAILURE RATE : 906.5 HRS		P
10	DMTBF/Accelerated Life Test	Demonstration Mean Time Between Failure(Expected Life) : 30,000 hours @ Tcase 75°C ; 50,000 hours @ Tcase 65°C		P

DATE	SAMPLE	TEST RESULT	TESTER	APPROVAL
2010/10/6	RD SAMPLE	PASS	SANFORD SU	VINCENT TSENG
2010/11/10	PRODUCT SAMPLE	PASS	SANFORD SU	VINCENT TSENG

2009/08/04 A50-F023